

**MARKING SCHEME CODE: D**

**SECTION A**

- |   |   |
|---|---|
| 1. (c) $-qLE$   | 1 |
| 2. (a) red colour   | 1 |
| 3. (c) 1 : 3  | 1 |
| 4. (d) $R = 0$  | 1 |
| 5. (a) Resistivity  | 1 |
| 6. (b) ferromagnetic material becomes paramagnetic                  | 1 |
| 7. (a) electric field is changing                                   | 1 |
| 8. (a) move in a straight line                                      | 1 |
| 9. (a) binding energy per nucleon increases                         | 1 |
| 10. (c) zero as diffusion and drift currents are equal and opposite | 1 |
| 11. (b) just below the conduction band                              | 1 |
| 12. (a) $\frac{1}{\epsilon_0}$                                      | 1 |
| 13. (d) $\frac{1}{n^2}$   | 1 |
| 14. (b) zero  | 1 |
| 15. (a) both A and R are true and R is the correct explanation of A | 1 |
| 16. (a) Both A and R are true and R is the correct explanation of A | 1 |
| 17. (d) A is false and R is also false                              | 1 |
| 18. (a) Both A and R are true and R is the correct explanation of A | 1 |

**SECTION B**

19. Energy band diagram	$\frac{1}{2} + \frac{1}{2}$
Significance	$\frac{1}{2} + \frac{1}{2}$

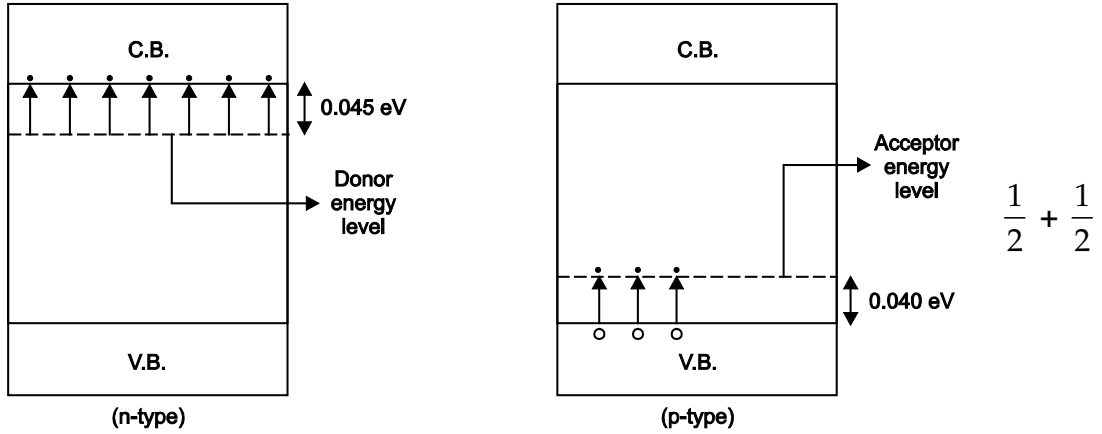

### Significance

*n*-type semiconductor– small energy gap b/w donor level and conduction band which can be easily covered by thermally excited electrons. ½

*p*-type semiconductors– small energy gap b/w acceptor level and valence band which can be easily covered by thermally excited electrons. ½

OR

When *p*-type semiconductor is joined with *n*-type semiconductor, *e* from the *n*-side diffuse towards *p*-side and holes from *p*-side diffuse towards *n*-sides leaving behind a layer of immobile +ve ions on *n*-side and immobile –ve ions on *p*-side leading to formation of depletion layer. 2

(Note: Award 1 mark, if a student draws a diagram showing depletion layer)

20. Arrangement	1
two uses	½ + ½

Radiowaves < microwaves < X-rays < gamma rays 1

#### Uses of microwaves

1. Microwave oven ½

2. in Rader system ½

21. Definition	1
Calculation of focal length	1

**One Dioptre** is the power of a lens whose focal length is one metre. 1

$$\frac{1}{f} = (\mu - 1) \left( \frac{1}{R_1} - \frac{1}{R_2} \right) \quad \frac{1}{2}$$

$$R_1 = \infty, \quad R_2 = -25 \text{ cm}, \quad \mu = 1.5$$

$$\frac{1}{f} = (1.5 - 1) \left( \frac{1}{\infty} + \frac{1}{25} \right)$$

$$f = 50 \text{ cm} \quad \frac{1}{2}$$

22. As	$V = \frac{q}{C}$	½
--------	-------------------	---

*dW* is the W.D. in giving additional charge *dq*

$$dW = V dq = \frac{q}{C} dq \quad \frac{1}{2}$$

$$\begin{aligned} W = \int dW &= \frac{1}{C} \int_0^Q q dq = \frac{1}{C} \left[ \frac{q^2}{2} \right]_0^Q \\ &= \frac{Q^2}{2C} \end{aligned}$$

This work done is stored in the form of energy of capacitor.

$$E = \frac{Q^2}{2C} = \frac{1}{2} CV^2 = \frac{1}{2} QV \quad 1$$

OR

field inside a conductor	1
just outside the sphere	1

(a) Inside a conductor the electric field is zero because charges reside on the surface of sphere. 1

(b)  $E = \frac{1}{4\pi\epsilon_0} \frac{q}{R^2}$  1/2

$$E = 9 \times 10^9 \times \frac{(1.6 \times 10^{-7})}{(12 \times 10^{-2})^2}$$

$$= 10^5 \text{ NC}^{-1} \quad 1/2$$

23. There are some devices which do not obey ohm's law and have non-linear I-V characteristics are called non-ohmic devices. 1

e.g., semiconductor devices like *p-n* junction diode, thermistors etc.

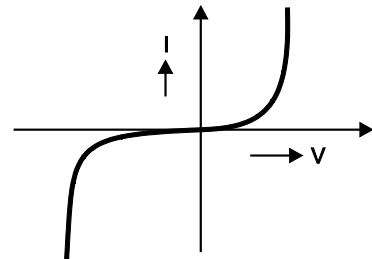

$$\frac{V}{I} = R \neq \text{constant}$$

(for *p-n* junction diode) 1

24. Magnetic field lines for a bar magnet and a current carrying solenoid resembles very closely. 1

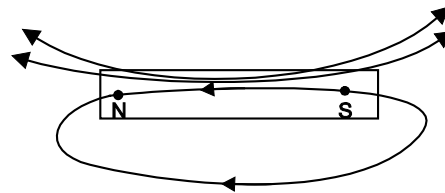
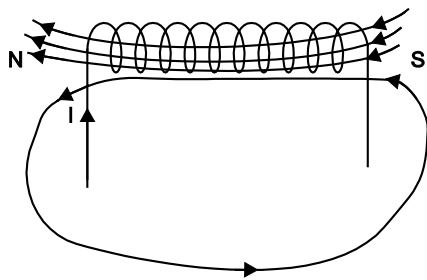

Magnetic field on the axial line of a bar magnet is equal to the magnetic moment of an equivalent solenoid that produces the same magnetic field.

$$B = \frac{\mu_0}{4\pi} \frac{2M}{r^3} \quad 1$$

25. Totally reflecting prisms are used to change the path of a ray by 90° or 180°. These are the right angled glass prisms of refractive index 1.5 and critical angle

41.8°. In totally reflecting glass prisms, angle of incidence is made 45° (> C). Hence light suffers total internal reflection. 1

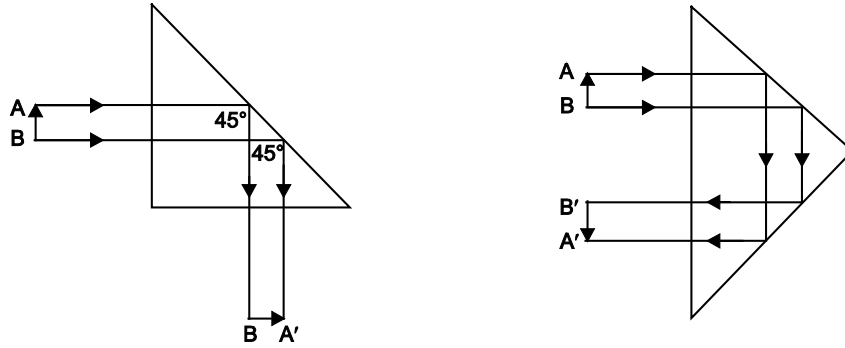

**SECTION C**

26.	Diagram	1
	Two advantages	1 + 1

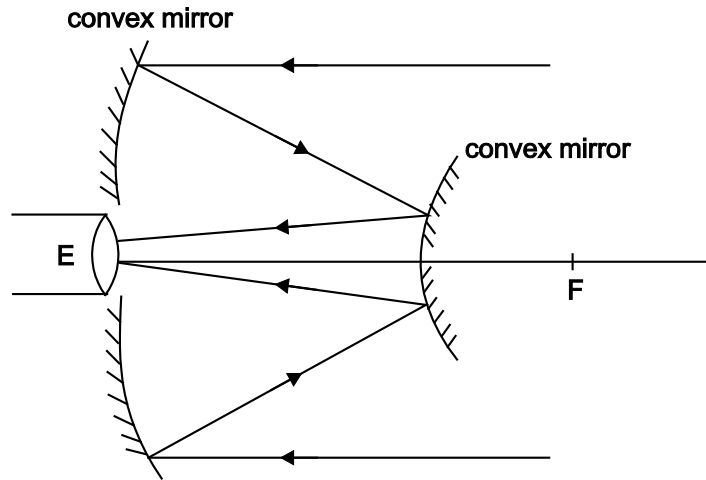

Cassegrainian Telescope

**Advantages:**

1. There is no chromatic aberration as the objective is a mirror.
2. Image is bright as compared to refracting type telescope. 1 + 1

OR

(i) Calculating fringe width	1
(ii) Distance of fringes	1 + 1

(i) 
$$\beta = \frac{\lambda D}{d} = \frac{600 \times 10^{-9} \times 1.6}{0.8 \times 10^{-3}}$$

$$= 1.2 \text{ mm}$$

1

$$(i) (a) \quad x_3 = \frac{5}{2} \frac{\lambda D}{d} = \frac{5}{2} \times 1.2$$

$$= 3 \text{ mm}$$

$$(b) \quad x_5 = \frac{5\lambda D}{d} = 5 \times 1.2$$

$$= 6.0 \text{ mm}$$

1

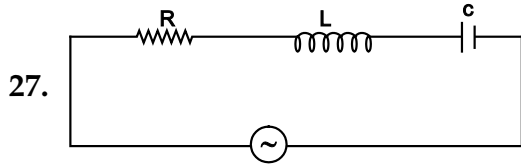

Let  $I = I_0 \sin \omega t$

$V_R = IR$  represented by  $OR$

$V_L = I X_L$  represented by  $OB$

$V_C = I X_C$  represented by  $OC$

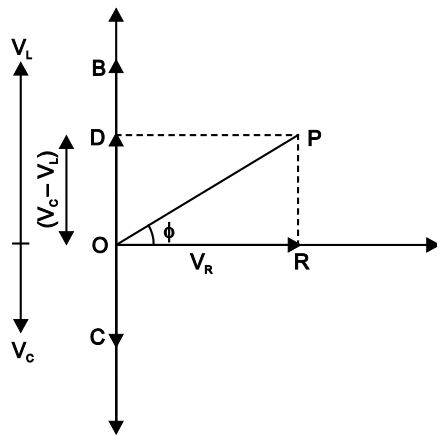

1

In  $\triangle OPR$

$$(OP)^2 = (OR)^2 + (PR)^2$$

$$V^2 = V_R^2 + (V_L - V_C)^2$$

$$E = V = I \sqrt{R^2 + (X_L - X_C)^2}$$

$$I = \frac{E}{\sqrt{R^2 + (X_L - X_C)^2}}$$

Here  $Z = \sqrt{R^2 + (X_L - X_C)^2}$  = Impedance of the circuit 1

Resistance offered by the  $L$ ,  $C$  and  $R$  to the flow of current.

### Impedance triangle

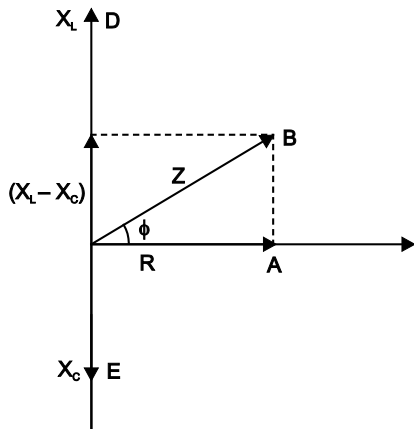

1

OR

At low frequency  $X_L$  is small but  $X_C$  is high and at high frequency  $X_L$  is high but  $X_C$  is small. But at a frequency when  $X_L = X_C$  called as resonant frequency Impedance of LCR is minimum and current through the circuit is maximum.

$$X_L = X_C$$

$$\omega L = \frac{1}{\omega C}$$

$$\omega^2 = \frac{1}{LC}$$

$$\omega = \frac{1}{\sqrt{LC}} \quad \omega - \text{Resonating angular frequency}$$

$$v = \frac{1}{2\pi\sqrt{LC}} \quad 1\frac{1}{2}$$

$$I_0 = \frac{E_0}{R} \quad (\text{max. at resonance})$$

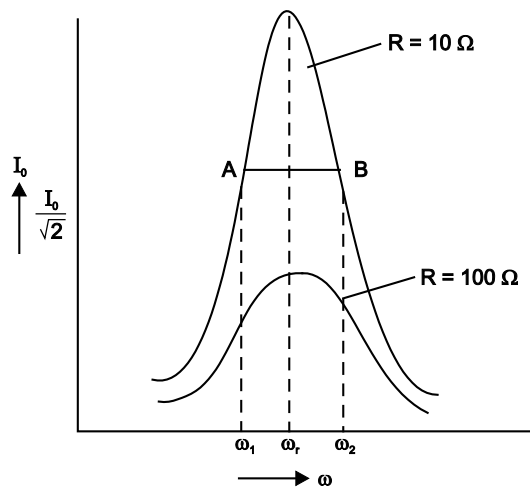

Q-factor is the sharpness of curve at resonance.

$$\text{Q-factor} = \frac{\text{Pot}^n \text{ drop across } L \text{ or } C}{\text{Pot}^n \text{ drop across } R \text{ at resonance}}$$

$$= \frac{I_0 X_L}{I_0 R} = \frac{\omega L}{R} \quad \text{and} \quad \omega = \frac{1}{\sqrt{LC}}$$

$$\text{Q-factor} = \frac{1}{R} \sqrt{\frac{L}{C}}$$

$1 \frac{1}{2}$

28.

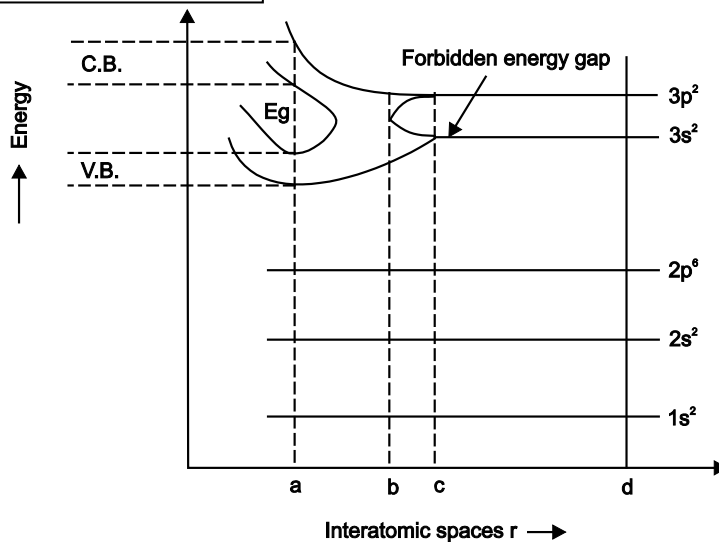

1

The process of splitting of energy levels can be understood by considering the different situations.

- (i) **When  $r = d$**  – No modification of energy levels.
- (ii) **When  $r = c$**  – Interaction b/w outermost shell electrons of neighbouring Si atoms increases and energy gap b/w  $2N - 3s$  levels and  $6N - 3p$  levels goes on decreasing.
- (iii) **When  $b < r < c$**  – Instead of single  $3s$  and  $3p$  level, we get large no. of closely packed level.
- (iv) **When  $r = b > a$**  – The energy gap b/w  $3s$  and  $3p$  levels completely disappears and all the  $8N$  levels are continuously distributed. One can say that  $4N$  levels are filled and  $4N$  levels are empty.
- (v) **When  $r = a$**  –  $4N$  filled levels get separated from  $4N$  empty levels.  $4N$  filled level form a band called valance band and  $4N$  empty levels form a band called conduction band.

2

29. Let us consider two charges  $-q$  and  $+q$  separated by certain distance  $2a$  form a dipole of moment  $p = q(2a)$

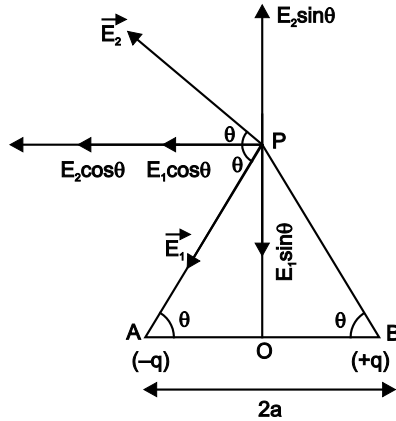

1

$$\vec{E}_1 = \frac{1}{4\pi\epsilon_0} \frac{q}{(r^2 + a^2)} \text{ along PA due to } -q \text{ charge}$$

$$\vec{E}_2 = \frac{1}{4\pi\epsilon_0} \frac{q}{(r^2 + a^2)} \text{ along extended BP due to } +q \text{ charge}$$

$$|\vec{E}_1| = |\vec{E}_2|$$

1

Resolve  $\vec{E}_1$  and  $\vec{E}_2$  as shown in fig.

Net electric field

$$E = E_1 \cos\theta + E_2 \cos\theta$$

$$= 2 E_1 \cos\theta$$

$$E = 2 \frac{1}{4\pi\epsilon_0} \frac{q}{(r^2 + a^2)} \cdot \frac{a}{(r^2 + a^2)^{3/2}}$$

$$E = \frac{p}{4\pi\epsilon_0 (r^2 + a^2)^{3/2}}$$

for ideal dipole  $2a \approx 0$

$$E = \frac{p}{4\pi\epsilon_0 r^3}$$

1

30. Application of KVL on loops	$1\frac{1}{2}$
Calculation of $I_1, I_2, I_3$	$1\frac{1}{2}$

**Apply KVL on loop EABCE**

$$10 = 10(I_1 + I_2) + 10I_1 + 5(I_1 - I_3)$$

$$2 = 5I_1 + 2I_2 - I_3$$

...(1)

**Apply KVL on loop ABDA**

$$10I_1 + 5I_3 - 5I_2 = 0$$

$$I_2 = 2I_1 + I_3$$

...(2)



Apply KVL on loop BCDB

$$5(I_1 - I_3) = 10 (I_2 + I_3) - 5 I_3 = 0$$

$$I_1 = 2I_2 + 4 I_3 \quad \dots(3)$$

On solving we get

$$I_1 = \frac{4}{17} \text{A}, \quad I_2 = \frac{6}{17} \text{A}, \quad I_3 = \frac{-2}{17} \text{A}$$

$$\therefore I_1 + I_2 = \frac{10}{17} \text{A}$$

$$I_1 - I_3 = \frac{6}{17} \text{A}$$

$$I_2 + I_3 = \frac{4}{17} \text{A}$$

### SECTION D

- |                              |   |
|------------------------------|---|
| 31. (i) (c) mutual Induction | 1 |
| (ii) (c) frequency           | 1 |
| (iii) (d) soft iron          | 1 |
| (iv) (b) 2A                  | 1 |

OR

- |   |   |
|---|---|
| (a) reduce the energy loss due to eddy currents |   |
| 32. (i) (a) Photoelectric effect                | 1 |
| (ii) (a) Photons exert no pressure              | 1 |
| (iii) (d) zero                                  | 1 |
| (iv) (b) No. of photons                         | 1 |

OR

$$E = n h\nu \quad \text{or} \quad n = \frac{E}{h\nu}$$

$$n = \frac{6.62}{(6.62 \times 10^{-34}) \times 10^{12}}$$

$$= 10^{22}$$

### SECTION E

33. Diagram	1
Observations	2
Distance of closest approach	2

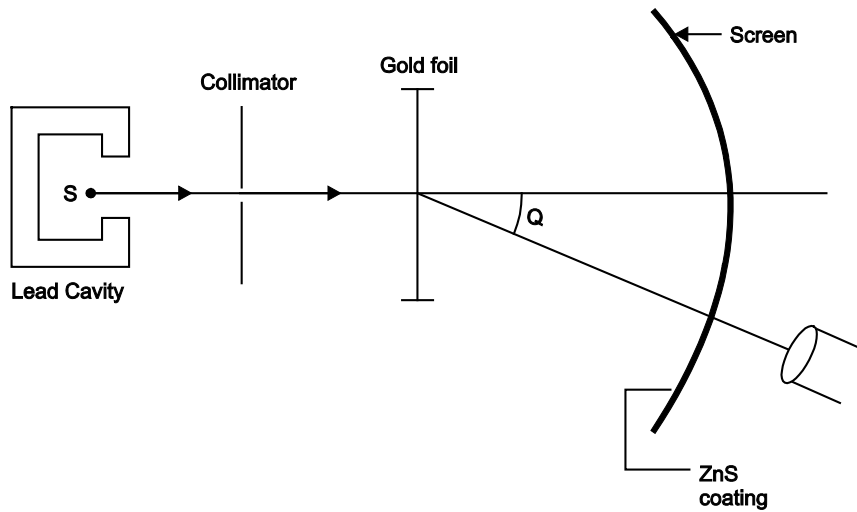

1

**Observations:**

1. Most of the  $\alpha$ -particles pass without deflection.
2. Large no. of  $\alpha$ -particles are scattered by very small angle.
3. Small no. of  $\alpha$ -particles are scattered by large angle.
4. A very few no. of  $\alpha$ -particles (1 in 8000) retraced their path.

2

**Distance of closest approach:** It is the minimum distance of  $\alpha$ -particle from nucleus at which K.E. converts into P.E.

K.E.  $\Rightarrow$  P.E.

$$\frac{1}{2}mv^2 = \frac{1}{4\pi\epsilon_0} \frac{(Ze)(2e)}{r_0}$$

$\therefore r_0 = \frac{Ze(2e)}{4\pi\epsilon_0 \left( \frac{1}{2}mv^2 \right)}$
---

OR

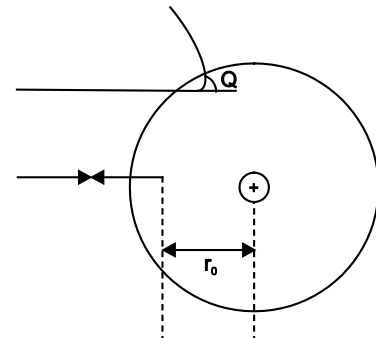

2

Difference b/w nuclear fusion and fission	$1\frac{1}{2} + 1\frac{1}{2} = 3$
de Broglie explanation	2

(i) **Nuclear fission:** It is a phenomenon of splitting of a heavy nuclei ( $A > 200$ ) into two or more lighter nuclei.

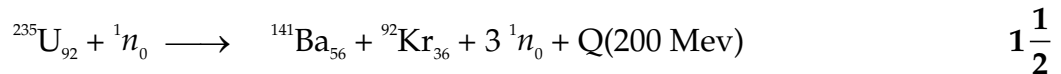

**Nuclear fusion:** It is the phenomenon of fusing two or more lighter nuclei to form a single heavy nucleus



(ii) Acc. to de Broglie, a stationary orbit is that which contains an integral number of de Broglie waves associated with revolving electron

Total distance covered  $2 \pi r_n$  1

$\therefore$  For permissible orbit  $2 \pi r_n = n\lambda$  ...(1)

Acc. to de brogile  $\lambda = \frac{h}{m v_n}$  Put in (1)

$$\Rightarrow 2 \pi r_n = \frac{nh}{m v_n}$$

or  $m v_n r_n = \frac{nh}{2\pi}$  1

which is the quantum condition proposed by Bohr in second postulate.

34.	Diagram	1
	principle	½
	Construction	1½
	working	2

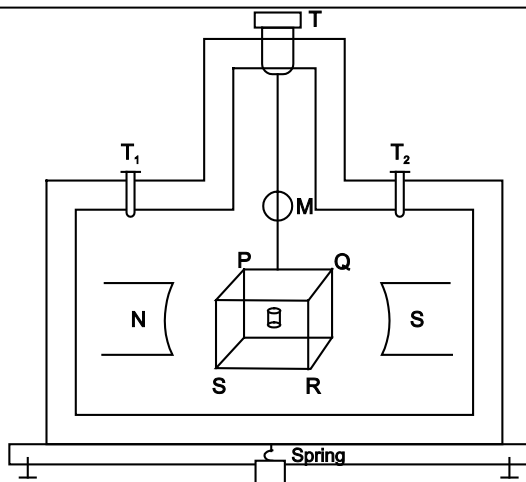

**Principle:** When a current carrying coil placed in magnetic field, it experiences a torque. ½

**Construction:** It consists of a rectangular coil PQRS of large no. of turns of insulated copper wire wound over a non-magnetic material frame. A soft iron cylindrical core is placed such that coil can rotate without touching it. Coil is suspended b/w two cylindrical magnets by a phosphor brozne wire. Upper end of the coil is connected to movable torsion head and lower end is connected to hair spring. 1½

**Working:** Function of cylindrical core and magnet is to provide radial magnetic field.

$$\tau = n I A B$$

If  $k$  is the restoring torque per unit twist and  $\theta$  be the twist in the wire.

In equilibrium

$$\tau = \tau_R \text{ (Restoring torque)}$$

$$n I A B = k\theta$$

$$I = \frac{k\theta}{n A B}$$

$$= G\theta \text{ where } G = \frac{k}{n A B} \text{ galvanometer constant}$$

$$I \propto Q$$

i.e., linear scale deflection

2

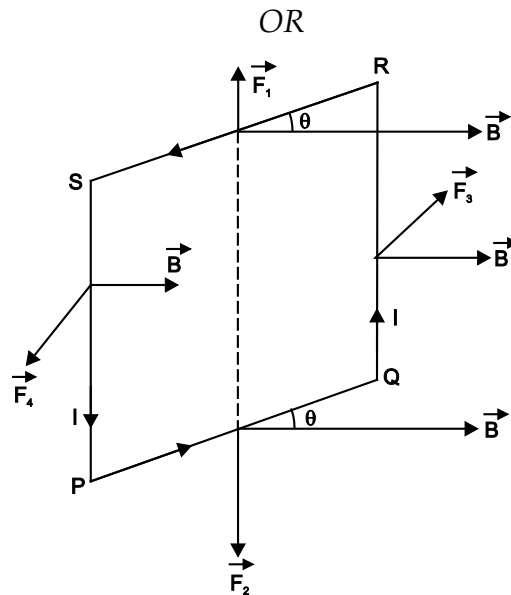

1

Consider a rectangular coil of length  $l$  breadth  $b$ .

$$SP = QR = l; \quad PQ = RS = b$$

$\theta$  angle made by plane of coil with mag. field

$\vec{F}_1 = lbB \sin\theta$  on  $RS$  acting  $\perp$  to both acting upward given by Right Hand Thumb Rule.

$\vec{F}_2 = lbB \sin\theta$  on  $PQ$  acting downward given by Right Hand Thumb Rule.

$\vec{F}_1$  &  $\vec{F}_2$  are equal and opposite hence cancel each other.

1

$\vec{F}_3 = I l B \sin 90^\circ = I l B$  acting on  $QR$  inwards by Fleming Left hand Rule.

$\vec{F}_4 = I l B \sin 90^\circ = I l B$  acting on  $SP$  outwards by Fleming Left hand Rule.

$\vec{F}_3$  &  $\vec{F}_4$  are equal but not acting along same line and form a couple which moves the coil in magnetic field.

1

Torque = force  $\times$  arm of couple.

$$\tau = I l B \text{ (RT)}$$

$$= I l B b \cos\theta$$

$$\tau = I A B \cos\theta$$

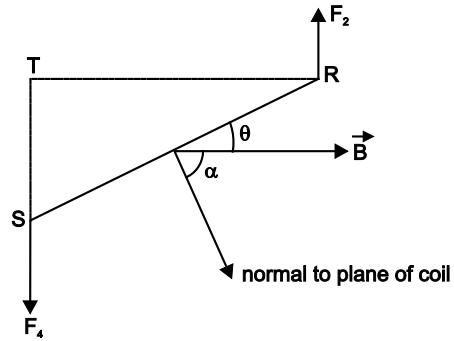

where  $A = lb =$  area of coils

Let  $\alpha$  is the angle b/w normal to the coil and magnetic field

then

$$\alpha + \theta = 90^\circ$$

$\therefore$

$$\theta = 90 - \alpha$$

If  $n$  - no. of turns then

$\therefore$

$$\tau = n I A B \cos (90 - \alpha)$$

$$= n I A B \sin \alpha$$

$$\tau = M B \sin \alpha \quad M\text{- mag. dipole moment}$$

$$\vec{\tau} = \vec{M} \times \vec{B}$$

2

35. (i) Ray diagram

1

Derivation

2

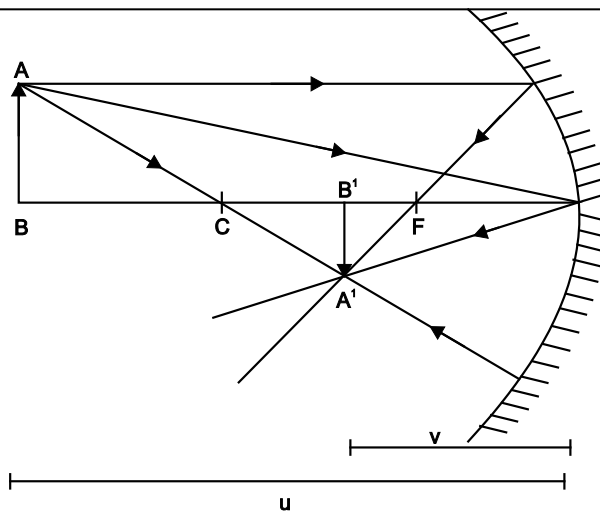

In  $\triangle ABP$  and  $\triangle A'B'P$

$$\frac{AB}{A'B'} = \frac{PB}{PB'} \quad \dots(1)$$

In  $\triangle ABC$  and  $A'B'C$

$$\frac{AB}{A'B'} = \frac{CB}{CB'} \quad \dots(2)$$

from (1) & (2)

$$\frac{PB}{PB'} = \frac{CB}{CB'} = \frac{PB - PC}{PC - PB'} \quad 1$$

$$PB = -u, \quad PB' = -v, \quad PC = -R$$

$$\frac{-u}{-v} = \frac{-u - (-R)}{-R - (-v)}$$

$$2uv = vR + uR$$

Divide by  $uvR$

$$\frac{2}{R} = \frac{1}{u} + \frac{1}{v}$$

$$\frac{1}{f} = \frac{1}{u} + \frac{1}{v} \quad \mathbf{1}$$

(ii) position of image	<b>1</b>
Nature and magnification	$\frac{1}{2} + \frac{1}{2} = \mathbf{1}$

$$u = -10 \text{ cm} \quad f = \frac{R}{2} = \frac{-15}{2} \text{ cm}$$

$$\frac{1}{f} = \frac{1}{u} + \frac{1}{v}$$

$$\frac{-2}{15} = \frac{1}{-10} + \frac{1}{v}$$

$$\frac{1}{v} = \frac{-2}{15} + \frac{1}{10}$$

$$v = -30 \text{ cm} \quad \mathbf{1}$$

Image is real and inverted  $\frac{1}{2}$

$$m = \frac{-v}{u} = -\frac{(-30)}{(-10)} = -3$$

Image is magnified 3 times.  $\frac{1}{2}$

OR

Def. of Refraction	<b>1</b>
Diagram	<b>1</b>
Derivation	<b>3</b>

Refraction of light is the phenomenon of change in path of light when it goes from one medium to another. **1**

Refraction from denser to rarer at convex spherical refracting surface.

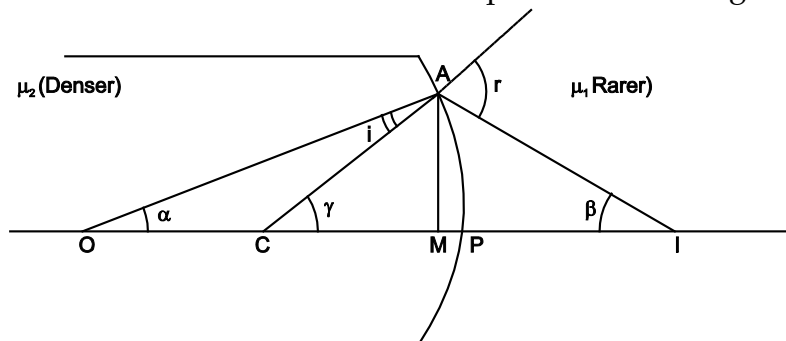

**1**

Apply Snell's law

$$\frac{\mu_1}{\mu_2} = \frac{\sin i}{\sin r} \approx \frac{i}{r}$$

$$\mu_1 r = \mu_2 i \quad \text{and} \quad r = \gamma + \beta \quad \dots(1)$$

$$i = \gamma - \alpha \quad \mathbf{1}$$

Put in (1)

$$\mu_1 (\gamma + \beta) = \mu_2 (\gamma - \alpha)$$

$$\mu_1 \left( \frac{AM}{MC} + \frac{AM}{MI} \right) = \mu_2 \left( \frac{AM}{MC} - \frac{AM}{MO} \right)$$

If aperture is small, then

$$\mu_1 \left( \frac{1}{PC} + \frac{1}{PI} \right) = \mu_2 \left( \frac{1}{PC} - \frac{1}{PO} \right)$$

$$PO = -u, \quad PC = -R, \quad PI = +v$$

$$\mu_1 \left( \frac{1}{-R} + \frac{1}{v} \right) = \mu_2 \left( \frac{1}{-R} - \frac{1}{-u} \right)$$

$$\frac{\mu_1}{-R} + \frac{\mu_1}{v} = \frac{\mu_2}{-R} - \frac{\mu_2}{-u}$$

$$\boxed{\frac{\mu_2}{-u} + \frac{\mu_1}{v} = \frac{\mu_1 - \mu_2}{R}}$$

**2**